



3379 Peachtree Road NE
Suite 555
Atlanta, GA 30326

SSX500 SEEDER

OPERATION AND PARTS

MANUAL



TO THE PURCHASER

This manual contains valuable information about your new Summit Tractor Seeder. It has been carefully prepared to give you helpful suggestions for operating, adjusting, servicing and ordering repair parts.

Keep this manual in a convenient place for quick and easy reference. Study it carefully. You have purchased a dependable and sturdy seeder, but only by proper care and operation can you expect to receive the service and long life designed and built into it.

Sometime in the future your seeder may need new parts to replace those that are worn or broken. If so, go to your dealer and provide him with the model and part number.

Customer Information

Name _____

Purchased From _____

Date Purchased _____

Model No. _____

Serial No. _____

It is the purchaser and/or operator's responsibility to....

- Read and understand the information contained in this manual.**
- Operate, lubricate, assemble and maintain the equipment in accordance with all instructions and safety procedures in this manual.**
- Inspect the equipment and replace or repair any parts that are damaged or worn which under continued operation would cause damage, wear to other parts, or cause a safety hazard.**
- Return the equipment or parts to the authorized Summit Tractor dealer, from where it was purchased, for service or replacement of defective parts that are covered by warranty. (The Summit Tractor Factory or an Authorized Summit Tractor Dealer may inspect equipment or parts before warranty claims are honored.)**

CONTENTS

ITEM	PAGE
Introduction.....	6
Safety Information	6
General Information.....	8
Getting Familiar with Your Seeder	10
Safety Training	11
Preparation & Starting and Stopping Safety	12
Operational Safety.....	13
Transport safety.....	14
Safety Signs	15
Attaching To Tractor.....	18
Sizing PTO	20
Maintenance & Storage Safety.....	21
Adjustments.....	22
Lubrication.....	28
Replace Spreader Vanes.....	29
Replacement Parts.....	30
Warranty	32

INTRODUCTION

The fertilizer spreaders are used for the distribution of solid granular fertilizers and seeds. They can be used with a tractor with small or medium horsepower. It is recommended to read this operator's manual and follow the recommendation to ensure safe and efficient operation.

This manual is to give the customer all the information and safety rules as well as use and maintenance instructions to get the best efficiency out of your seeder. The manual should always be available so it can be consulted when questions arise. If you lose or your copy or it gets destroyed you may request a copy from your dealer. If you have an issue with images or instructions please contact your dealer or manufacturer.

SAFETY

READ AND FOLLOW THE INSTRUCTIONS IN THIS MANUAL AND ESPECIALLY IN THE SAFETY SECTION. FAILURE TO DO SO CAN RESULT IN SERIOUS INJURY OR DEATH.

TAKE NOTE! THIS SAFETY ALERT SYMBOL FOUND THROUGHOUT THIS MANUAL IS USED TO CALL YOUR ATTENTION TO INSTRUCTIONS INVOLVING YOUR PERSONAL SAFETY AND THE SAFETY OF OTHERS.



THIS SYMBOL MEANS
ATTENTION! BECOME ALERT!
YOUR SAFETY IS INVOLVED

SIGNAL WORDS:

The signal words **DANGER**, **WARNING** and **CAUTION** are used with the safety messages in this manual and with each safety signs. They are defined as follows:

DANGER: Indicates an immediate hazardous situation that, if not avoided, could result in serious injury or death. This signal word is to be limited to the most extreme situations typically for machine components that, for functional purposes, cannot be guarded.

WARNING: Indicates a potentially hazardous situation that, if not avoided, could result in serious injury or death, and includes hazards that are exposed when guards are removed. It may also be used to alert against unsafe practices.

CAUTION: Indicates a potentially hazardous situation that, if not avoided, may result in minor or moderate injury. It may also be used to alert against unsafe practice.

If you have any questions not answered in this manual or require additional copies or the manual is damaged, please contact your dealer or Summit Tractor LLC 3379 Peachtree Road NE Suite 555 Atlanta, GA 30326 (678) 916-6555.

EQUIPMENT SAFETY GUIDELINES



- Safety of the operator and by standards is one of the main concerns in designing and developing a seeder. However, every year accidents occur which could have been avoided by a few seconds of thought and a more careful approach to handling equipment. You, the operator, can avoid many accidents by observing the following precautions and insist those working with you, or for you, follow them.
- In order to provide a better view, certain photographs or illustrations in this manual may show an assembly with a safety shield removed. However, equipment should never be operated in this condition. Keep all shields in place. If shield removal becomes necessary for repairs, replace the shield prior to use.
- Replace any safety sign that is not readable or is missing. Location of such safety signs is indicated in this manual.
- Never use alcoholic beverages or drugs that can hinder alertness or coordination while operating this equipment. Consult your doctor about operating this machine while taking prescription medications.
- **Under no circumstances should children under the age of 18 be allowed to work with this equipment. Do not allow persons to operate or assemble this unit until they have read this manual and have developed a thorough understanding of the safety precautions and of how it works. Review the safety instructions with all users annually.**
- This equipment is dangerous to children and persons unfamiliar with its operation. The operator should be a responsible, properly trained and physically able person familiar with farm machinery and trained in this equipment's operations. If the elderly are assisting with farm work, their physical limitations need to be recognized and accommodated.
- Use a tractor equipped with a Roll Over Protective System and seat belts. (ROPS)
- Never exceed the limits of a piece of machinery. If its ability to do a job, or to do so safely, is in question- **DON'T TRY IT.**
- Do not modify the equipment in any way. Unauthorized modification could result in serious injury or death and may impair the function and life of the equipment.
- In addition to the design and the confirmation of this implement, including safety signs and safety equipment, hazard control and accident prevention are dependent upon the awareness, concern, prudence, and proper training of personnel involved in the operation, transport, maintenance, and storage of the machine. Refer also to safety messages and operation instruction in each of the appropriate sections of the tractor and seeder manuals. Pay close attention to the safety signs affixed to the tractor and the seeder.

GENERAL INFORMATION

The models in this manual have been designed and made exclusively for the distribution of solid, granular fertilizers and seeds. It is not designed to spread anything else.

These seeders are usually used during the daylight hours. If you are required to use it at night with poor visibility, you will need to use the lighting from your tractor or the equipment you have the seeder attached to see properly.

Any modification made to this seeder relieves the manufacturer from any responsibility for damages to seeder, operator or any third party involved.

NAME PLATE

On every seeder there is a name plate bar code that shows the model, serial number and UPC number for your seeder. When spare parts are needed it is necessary to be able to provide Model and serial number to ensure the correct parts.



CHARACTERISTICS OF THE SEEDER

The hardness of the steel welded frame together with the life of the hoppers, let's you obtain the highest quality level of seeders. The paint is epoxy varnish with successive baking at 150° Celsius (302° F) with the application of a primer bath, assuring great protection and long life of the seeder.

The seeder has a distributor, equipped with a spreader disc with (4) adjustable veins, with (4) different position settings. To obtain the maximum spreading precision and uniformity in the distribution, depending on the kind of material that must be spread.



The seed or fertilizer is gravity fed through an opening, located on the bottom of the hopper, which has a agitator inside to prevent lumps in your material. A guard is located on the front side facing tractor to prevent material being fed towards the tractor.

The material delivery is controlled by using the proper opening setting on the gates at the hopper bottom. The spreader is connected through a gearbox.

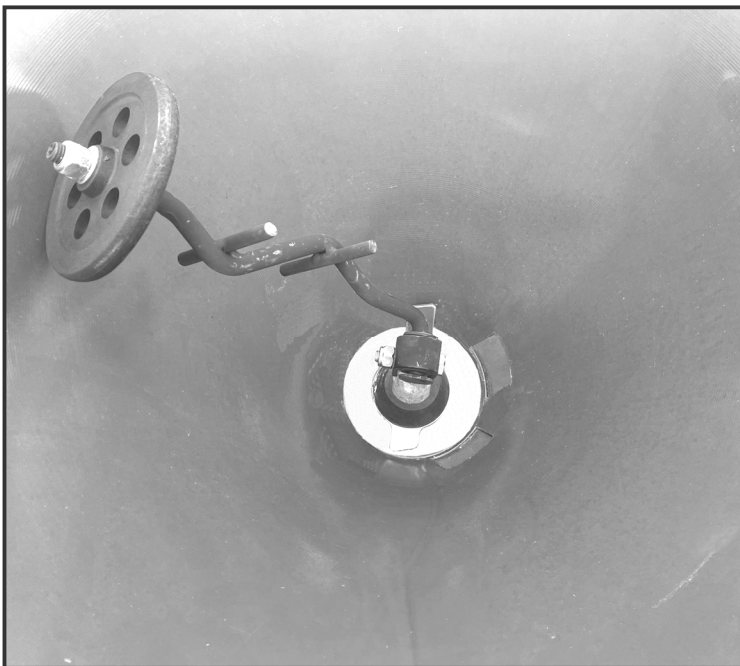

GETTING FAMILIAR WITH YOUR SEEDER

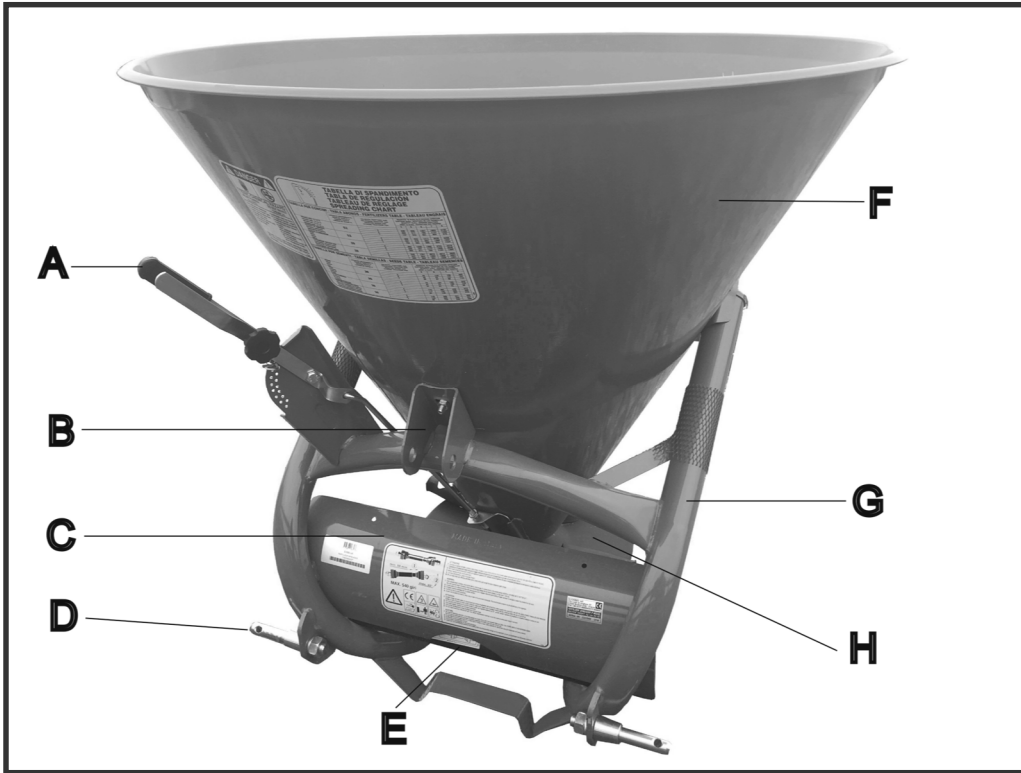

- A. Regulating lever
- B. Top Link Connection
- C. Spreading Guard
- D. Lift Pin
- E. Gearbox Shaft to PTO
- F. Hopper
- G. Steel Frame
- H. Distributor Vanes

The manufacturer is not responsible in case of:

- Improper use of seeder, or used by a person that has not been trained.
- Seeder not maintained.
- Changes or modifications of the seeder.
- Use of non original parts.
- Total or partial lack of attention of the instructions.
- Not observing the safety rules.
- Seeder used for non intended jobs.

SAFETY TRAINING



- I Safety is a primary concern in the design and manufacture of our product. Unfortunately, our efforts to provide safe equipment can be wiped out by a single careless act of an operator or bystander.

- I In addition to the design and configuration of equipment, hazard control and accident prevention are dependent upon the awareness, concern, prudence and proper training of personnel involved in the operation, transport, maintenance and storage of this equipment.

- I It has been said, “ The best safety device is an informed, careful operator.” We ask you to be that kind of operator. It is the operator’s responsibility to read and understand all safety and operating instructions in the manual and to follow them. Accidents can be avoided.

- I Working with unfamiliar equipment can lead to careless injuries. Read this manual, and the manual for your tractor, before assembly or operating, to acquaint yourself with the machines. If this machine is used by any person other than you, or is loaned or rented, it is the seeder owner’s responsibility to make certain that owner's manual be available to the operator prior to operating:
 - 1- Reads and understands the operator’s manuals.
 - 2- Is instructed in safe and proper use.

- I Know your controls and how to stop tractor, engine, and the seeder quickly in an emergency. Read this manual and the one provided with your tractor.

- I Train all new personnel and review instructions frequently with existing workers. Be certain only a properly trained and physically able person will operate the machinery. A person who has not read and understood all operating and safety instructions is not qualified to operate the machine. An untrained operator exposes himself and by standers to possible serious injury or death. If the elderly are assisting with farm work, their physical limitations need to be recognized and accommodated.

PREPARATION



- I Never operate the tractor and seeder until you have read and completely understand this manual, the Tractor Operator's Manual, and each of the safety messages found on the safety signs on the tractor and seeder.
- I Personal protection equipment including hardhat, safety glasses, safety shoes, and gloves are recommended during assembly, installation, operation, adjustment, maintenance, repairing, removal, or moving the implement. Do not allow long hair, loose fitting clothing, or jewelry to be around equipment.
- I **PROLONGED EXPOSURE TO LOUD NOISE MAY CAUSE PERMANENT HEARING LOSS!** Tractors with or without seeders attached can often be noisy enough to cause permanent, partial hearing loss. We recommend that you wear hearing protection on a full-time basis if the noise in the operator's position exceeds 80 db. Noise over 80 db on a long-term basis can cause severe hearing loss. Noise over 90 db adjacent to the operator over a long-term basis may cause permanent, total hearing loss. **NOTE:** Hearing loss from loud noise (from tractors, chain saws, radios, and other such sources close to the ear) is cumulative over a lifetime without hope of natural recovery.
- I Operate the seeder only with a tractor equipped with an approved Roll-Over-Protective System (ROPS). Always wear your seat belt. Serious injury or even death could result from falling off the tractor — particularly during a turnover when the operator could be pinned under the ROPS or the tractor.
- I Clear area of stones, branches or other debris that might , cause injury or damage.
- I Operate only in daylight or good artificial light.
- I Ensure seeder is properly mounted, adjusted and in good operating condition.
- I Ensure that all safety shielding and safety signs are properly installed and in good condition.

STARTING AND STOPPING SAFETY



- I Check the tractor master shield over the PTO stub shaft. Make sure it is in good condition and fastened securely to the tractor. Purchase a new shield if old shield is damaged or missing.
- I All tractors that are not equipped with a "live" power takeoff (PTO) need to be equipped with an over-running PTO clutch. These are available through most farm equipment stores. **NOTE:** The addition of an over-running PTO clutch may change the length of the PTO driveline required. Pay extra attention to the instructions on the PTO driveline Installation. Be sure that the driveline system guarding is adequate.
- I Seeder operating power is supplied from tractor PTO. Refer to your tractor manual for PTO engagement and disengagement instructions. Know how to stop tractor and seeder quickly in case of an emergency.
- I When engaging PTO, the engine RPM should always be at idle speed. Once engaged and ready to start spreading, raise PTO speed to 540 RPM and maintain throughout spreading operation.

OPERATIONAL SAFETY



- I The use of this equipment is subject to certain hazards that cannot be protected against by the mechanical means or product design. All operators of this equipment must read and understand this entire manual, paying particular attention to safety and operating instructions, prior to using. If there is something in this manual you do not understand, ask your supervisor, or your dealer, to explain it to you.
- I Most accidents occur because of neglect or carelessness. Keep all helpers and bystanders at least several hundred feet from an operating seeder. Only properly trained people should operate this machine.
- I When machine is operated in populated areas where thrown objects could injure persons or property, **operation must be stopped when anyone comes within several hundred feet.**
- I The majority of the accidents involve entanglement on the driveline and injury of operators being knocked off the tractor by low hanging limbs and then being run over by the tractor and seeder. Accidents are most likely to occur with machines that are loaned or rented to someone who has not read the owner's manual and is not familiar with a seeder.
- I The seeder is designed for use only on tractors with **540-RPM** power take off.
- I Install and secure all guards and shields before starting or operating. The spreading disc, agitator, driveline guards and tractor, shields should be used and maintained in good working condition. They should be inspected carefully, at least daily, for missing or broken parts, chain links, shields, or guards. (Worn items must be replaced at once to reduce possibility of injury)
- I Disengage power takeoff (PTO) and place transmission in neutral before attempting to start engine.

OPERATIONAL SAFETY continued...



- I Pass seeder diagonally through sharp dips and avoid sharp drops to prevent “hanging up” tractor and seeder. Practice will improve your skills in maneuvering on rough terrain. Always check tractor manual for proper use on slopes.
- I When using a unit, a minimum 20% of tractor and equipment weight must be on tractor front wheels. Without this weight, tractor could tip over, causing personal injury or death. The weight may be attained with a front- end loader, front wheel weights, ballast in the tires or front tractor weights. When attaining a minimum 20% of tractor and equipment weight on the front wheels, you must not exceed the ROPS weight certification. Weigh the tractor and equipment. **Do not guess or estimate!**

TRANSPORT SAFETY



- I Comply with state and local laws governing highway safety and movement of farm machinery on public roads.
- I The use of flashing amber lights is acceptable in most localities. However, some localities prohibit their use. Local laws should be checked for all lighting and marking requirements.
- I At all times, when driving the tractor and equipment on the road or highway under 20 mph (32 kph) use flashing amber warning lights and a slow moving vehicle (SMV) identification emblem. Do not exceed 20 mph (32 kph). Reduce speed on rough roads and surfaces.
- I Plan your route to avoid heavy traffic.
- I Always install transport locks, pins or brackets before transporting.
- I Do not drink and drive.
- I Be a safe and courteous driver. Always yield to oncoming traffic in all situations, including narrow bridges, intersections, etc. Watch for traffic when operating near or crossing roadways.
- I Turn curves or go up or down hills only at a low speed and at a gradual steering angle.
- I Use extreme care and maintain minimum ground and when operating close to ditches or fences. Be careful when turning sharp corners.
- I Never allow riders on either tractor or seeder.

SAFETY SIGNS

ATTENTION! Be sure that the safety labels are legible. Clean them up using a cloth, water and soap. Replace damaged labels placing them in the correct position.



The safety signs on the unit supplies you with important information: following those precautions help you to be safe as possible.





DANGER



TOXIC CHEMICAL HAZARD

WEAR RUBBER GLOVES **DO NOT INGEST CHEMICAL**

- Do not allow chemical or solution to touch skin. Some can be absorbed through the skin.
- Wear rubber gloves and protective gear at all times
- Chemicals can be toxic -If in eyes or mouth, read chemical manufacturers instructions and follow exactly.
- Seek medical attention immediately.
- A poison control number is normally inside the front cover of your telephone book.

FAILURE TO FOLLOW THESE INSTRUCTIONS WILL RESULT IN SERIOUS INJURY OR DEATH

1

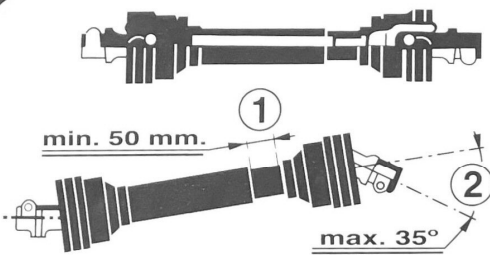

MAX. 540 giri



ATTENZIONE

- 1 Controllare la lunghezza dell'albero cardanico, assicurandosi che abbia un giuoco minimo di 50 mm. di scorrimento assiale nella posizione piu corta (N.B. NON DEVE ASSOLUTAMENTE FORZARE). Controllare poi la lunghezza del cardano nel punto di maggior estensione ed assicurarsi che l'accoppiamento tra gli alberi non sia inferiore ai 100 mm.
- 2 N.B. E' buona norma non far lavorare il cardano con angolazioni superiori ai 35°, pertanto durante le operazioni di carico e consigliabile disimpegnare la trasmissione di potenza dell'attrezzo.
- 3 Montare l'agitatore solo per concimi pulverulenti.
- 4 Controllare periodicamente il grasso nel gruppo d'angolo.
- 5 Per una lunga durata e per l'efficienza dell'attrezzo pulire a fondo tutte le parti ad ogni fine lavoro mediante un getto d'acqua.

WARNING

- 1 Check collapsed length of driveline, ensuring that there is a minimum gap of 2 inches (50 mm) in the shortest position (NEVER ALLOW DRIVELINE TO "BOTTOM OUT"). Also check maximum length of driveline to ensure the inserted length between the two halves (overlap) is not less than 4" (100 mm).
- 2 It is good practice not to operate the driveline with yoke angularity over 35 degrees. Hence during the loading of hopper operation it is advisable to detach the driveline from the tractor.
- 3 The agitator should be assembled ONLY for powder fertilizers.
- 4 The drive unit must be greased periodically.
- 5 All parts must be cleaned accurately by using a spray of water at the end of every working day. This should be done to improve long life and efficiency of the implement.

ATTENTION

- 1 Contrôler la longueur de l'arbre cardan, en s'assurant que le jeu minimum de glissement axial est de 50 mm. dans la position plus courte (N.B. IL NE DOIT PAS ABSOLUMENT TRAVAILLER SOUS PRESSION). Contrôler, en suite, la longueur du cardan au point d'extension majeure pour s'assurer que le couplage d'insertion des deux moitiés de l'arbre n'est pas moins de 100 mm.
- 2 N.B. Il est bonne norme operative de ne pas faire travailler le cardan avec angulation supérieure aux 35°, pourtant, pendant l'opération de chargement on conseille de détacher le cardan de l'outil.
- 3 Il faut monter l'agitateur seulement pour les engrais pulverulents.
- 4 Il faut contrôler périodiquement le niveau de graisse dans le groupe d'angle.
- 5 Pour une longue durée et pour l'efficacité de l'outil, il faut nettoyer soigneusement moyennant un jeu d'eau toutes les pièces après chaque fin de travail.



ACHTUNG

- 1 Die Länge der Gelenkwelle überprüfen, um ein Gleitungs spiel von mindst. 50 mm. axial in der kürzesten Stellung zu haben. (N.B. ES MUSS ABSOLUT KEIN EINTREIBEN GEBEN). Dann die Länge der Gelenkwelle bei der grössten Erstreckung überprüfen. Der Wellen muss nicht unter 100 mm. sein.
- 2 Eine gute Massnahme ist die gelenkwelle nicht mit Winkel ober 35° arbeiten zu lassen. Daher empfehlen wir, während der Ladung die Gelenkwelle vom Gerät zu betreiben.
- 3 Das Rührwerk nur bei Düngemitteln montieren.
- 4 Den Schmierfett im Winkelaggregat von Zeit zu Zeit kontrollieren.
- 5 Jeweils nach der Arbeitsbeendigung sämtliche Teile sorgfältig mittels eines Wasserstrahles reinigen um eine lange Dauer und die Leistungsfähigkeit des Werkzeuges zu erreichen.

109



DANGER

THROWN OBJECT / ROTATING PADDLES HAZARD

To prevent serious injury or death:

- Keep away from discharge area and rotating paddles during operation.
- Keep others away.
- Disconnect and lockout power source BEFORE adjusting or servicing.
- DO NOT point discharge towards people, animals, or buildings when operating.
- Keep hands, feet, hair, and clothing away from moving parts.

818-539C
200

3

SPREADING CHART

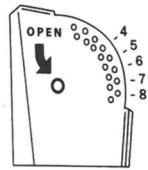

FERTILIZER TYPE	WORKING WIDTH FT.	TRACTOR SPEED MPH	QUANTITY LBS./ACRE - SHUTTER OPENING				
			4	5	6	7	8
GRANULAR 12-12-12	52	3	133	332	509	730	886
		5	83	207	318	456	553
		7	55	138	227	326	395
AMMONIUM NITRATE	52	3	149	373	572	821	995
		5	94	233	358	513	622
		7	62	155	238	342	577
UREA	39	3	199	497	763	1094	1326
		5	124	311	477	684	829
		7	83	207	318	456	553
GRANULAR CYANMIDE	39	3	219	547	839	1204	1460
		5	136	342	524	752	911
		7	91	228	350	502	608

SEED TYPE	WORKING WIDTH FT.	TRACTOR SPEED MPH	QUANTITY LBS./ACRE - SHUTTER OPENING			
			5	6	7	8
WHEAT/BARLEY	26	3	32	53	80	107
		5	19	33	49	65
		7	14	23	36	47
OATS/RYE	26	3	36	59	90	120
		5	21	35	54	72
		7	13	21	33	42
ALFALFA & CLOVER RED CLOVER	26	3	70	116	174	232
		5	47	79	117	156
		7	34	56	84	112
KENTUCKY & BERMUDA GRASS/FESCUE	26	3	71	121	179	241
		5	50	83	125	161
		7	36	62	89	121
SUDAN GRASS	26	3	80	135	180	260
		5	48	81	108	156
		7	34	57	77	111

NOTE: Spread Chart settings are approximate – always make a trial run to check actual application rate.

4

ATTACHING TO TRACTOR



WARNING



Never stand between tractor and seeder while backing up tractor to the hitch.

STEP 1 Slowly back tractor up to the seeder while using tractor's 3-Point hydraulic control lever to align hitch holes in lower arms with lower hitch pins.

STEP 2 Engage tractor park brake, shut tractor engine off, and remove key before dismounting from tractor.

STEP 3 Ensure that the lower hitch arms are blocked to prevent excessive side movement.

STEP 5 With tractor's lower hitch arms aligned and positioned correctly, attach arms to hitch pins and secure with linchpins.

STEP 6 Connect top center link to upper pivot hitch using customer supplied clevis pin and linchpin.

STEP 7 Return to tractor and slowly operate controls up and down to make sure the spreader clears tractor tires, frame and drawbar. Move or remove the drawbar if it interferes with the spreader.

STEP 8 Adjust 3-point hitch so that the seeder is horizontal.

STEP 9 Manually adjust length of top-link to level seeder from front to rear.

STEP 10 Determine if the PTO shaft needs to be shortened.

NOTE:

Due to the many variations in the tractor hitch points and distances between equipment gearbox input shaft and tractor PTO out put shafts, some combinations may require PTO shafts to be shortened as described by the following steps.

STEP 11 Raise and lower seeder in order to locate the shortest distance between equipment gearbox input shaft and tractor PTO output shaft. With the seeder in the shortest distance position shut down the tractor and **SECURELY BLOCK SEEDER IN POSITION.**

STEP 12 Pull apart PTO shaft and attach outer section to tractor PTO output shaft. **NOTE:** Be sure to pull on PTO shaft section to ensure yoke has locked into place.

ATTACHING TO TRACTOR *continued....*

STEP 13 Place and hold inner PTO shaft section next to outer section and check if PTO shaft is too long. Each section should end approximately 3 inches short of reaching u-joint shield on the opposite section. If the shaft is too long measure 3 inches back from each u-joint shield and mark the other shaft section. Be sure to do this for both PTO shaft halves. NOTE: Do not cut PTO shaft sections at this time.

STEP 14 Raise seeder and remove blocking. Raise and lower seeder in order to locate the longest distance between equipment input shaft and the tractor PTO output shaft. With the seeder in the longest distance position shut down the tractor and **SECURELY BLOCK THE SEEDER IN POSITION.**

STEP 15 As in step 5 hold PTO shaft sections together and check for a minimum of 6 inches of overlap. If PTO shaft has been marked for cutting the overlap is the distance measured between the two marks. If the PTO shaft has less than a 6 inch overlap, **DO NOT USE.** Contact your authorized Summit Tractor Dealer.

NOTE If the PTO shaft length is too long go to **SIZING PTO SHAFT (pg. 20)**

STEP 16 Apply any multi-purpose grease to the outside of the male (inner) PTO shaft section. Assemble PTO shaft and install on seeder and tractor.

WARNING - Failure to install retaining clip on gearbox input shaft would allow driveline to swing freely if bolt is sheared causing possible injury or death.

STEP 17 Pull on tractor side of PTO shaft yoke to be sure it has locked in place. Make certain PTO shaft shielding is in place and good working condition.

STEP 18 The PTO shaft shield is a non-rotating design and must be secured prior to equipment use. Using the chain on each yoke shield attach to a fixed object on the tractor and equipment ends that will not allow the PTO shaft shield to rotate during operation.

SIZING PTO SHAFT

STEP 1

Cutting the PTO shaft to length. **NOTE:** Be sure to cut equal lengths of each PTO shaft section. Clamp end of PTO shaft in a vice and cut off shield where marked. (Figure 1-A & 1-B)



Figure 1-A

STEP 2

Using cut section of the shield as a guide cut shaft off the same amount. (Figure 2)



Figure 1-B

STEP 3

Repeat steps 1 and 2 for other PTO shaft section.

STEP 4

Use a file to deburr PTO shafts. Clean up all chips, burrs and filings from both ends of the PTO shaft.

Note: If you shear the bolt that attaches the PTO shaft to the gearbox replace with a grade 2 bolt only. Replacement with another grade of bolt will void your warranty and may cause terminal damage to the PTO shaft, gearbox, or tractor.



Figure 2

MAINTENANCE SAFETY



- I Good maintenance is your responsibility. Poor maintenance is an invitation to trouble.
- I Follow good shop practices.
- I Keep service area clean and dry
- I Be sure electrical outlets and tools are properly grounded
- I Use adequate light for the job at hand.
- I Make sure there is plenty ventilation. Never operate the engine of the towing vehicle in a closed building. The exhaust fumes may cause asphyxiation.
- I Before working on this machine, disengage the PTO, shut off the engine, set the brakes, and remove the ignition keys.
- I Be certain all moving parts on attachments have come to a complete stop before attempting to perform maintenance.
- I Never work under equipment unless it is blocked securely.
- I Always use personal protection devices such as eye, hand and hearing protectors, when performing any service or maintenance.
- I Periodically tighten all bolts, nuts, and screws and check that all cotter pins are properly installed to ensure unit is in safe condition.
- I When completing a maintenance or service function, make sure all safety shields and devices are installed before placing unit in service.
- I After servicing, be sure all tools, parts and service equipment are removed from seeder.
- I Do not allow debris, grease or oil to build up on any part of the seeder.
- I Where replacement parts are necessary for periodic maintenance and servicing, genuine factory replacement parts must be used to restore your equipment to original specifications.
- I The manufacturer will not be responsible for injuries or damages caused by use of unapproved parts and/or accessories.
- I A fire extinguisher and the first aid kit should be kept readily accessible while performing maintenance on this equipment.

STORAGE SAFETY



- I Following operation, or when unhooking the seeder, stop the tractor, set the brakes, disengage the PTO, shut off the engine and remove the ignition keys.
- I Store the unit in an area away from human activity.
- I Do not park equipment where it can be exposed to direct contact to livestock for long periods of time. Damage and livestock injury could result.
- I Make sure all parked machines are on a hard, level surface and engage all safety devices.

STORAGE SAFETY continued...

- **The fertilizers are generally corrosive. For this reason it is important that no particles of fertilizer remains on the seeder for long periods of time.**
- Wash the hopper and seeder thoroughly when planning to store.
- Lubricate to prevent moisture damage and rust during storage.
- Sand areas where paint is chipped or worn and repaint to prevent rust.

NOTE: To distribute product more uniformly, operate spreader only on calm (non windy) days.

NOTE: To ensure full coverage (without skips), set spreader to disperse product at half the rate and go over the field plot twice using a 2nd pattern that crosses the first pattern.

ADJUSTMENTS

Distributor Vane Adjustment

Product distribution varies depending on travel speed, radius of distribution, and roughness of terrain. Also specific gravity, quality, and humidity of the product can effect distribution. To help ensure even distribution, the operator can adjust the distributor vanes to different hole locations on the spreader disc.

Refer to Figure 3: Page 23

When all vanes are placed in hole #1, distribution of product to the left is increased. If inserted into hole #4, distribution to the right is increases.

Final adjustment of the vanes depends upon the type of material being used and the operator's experience.

1. Loosen bolt (#1).
2. Rotate distributor vanes (#2) to desired hole position.
3. Tighten bolts.

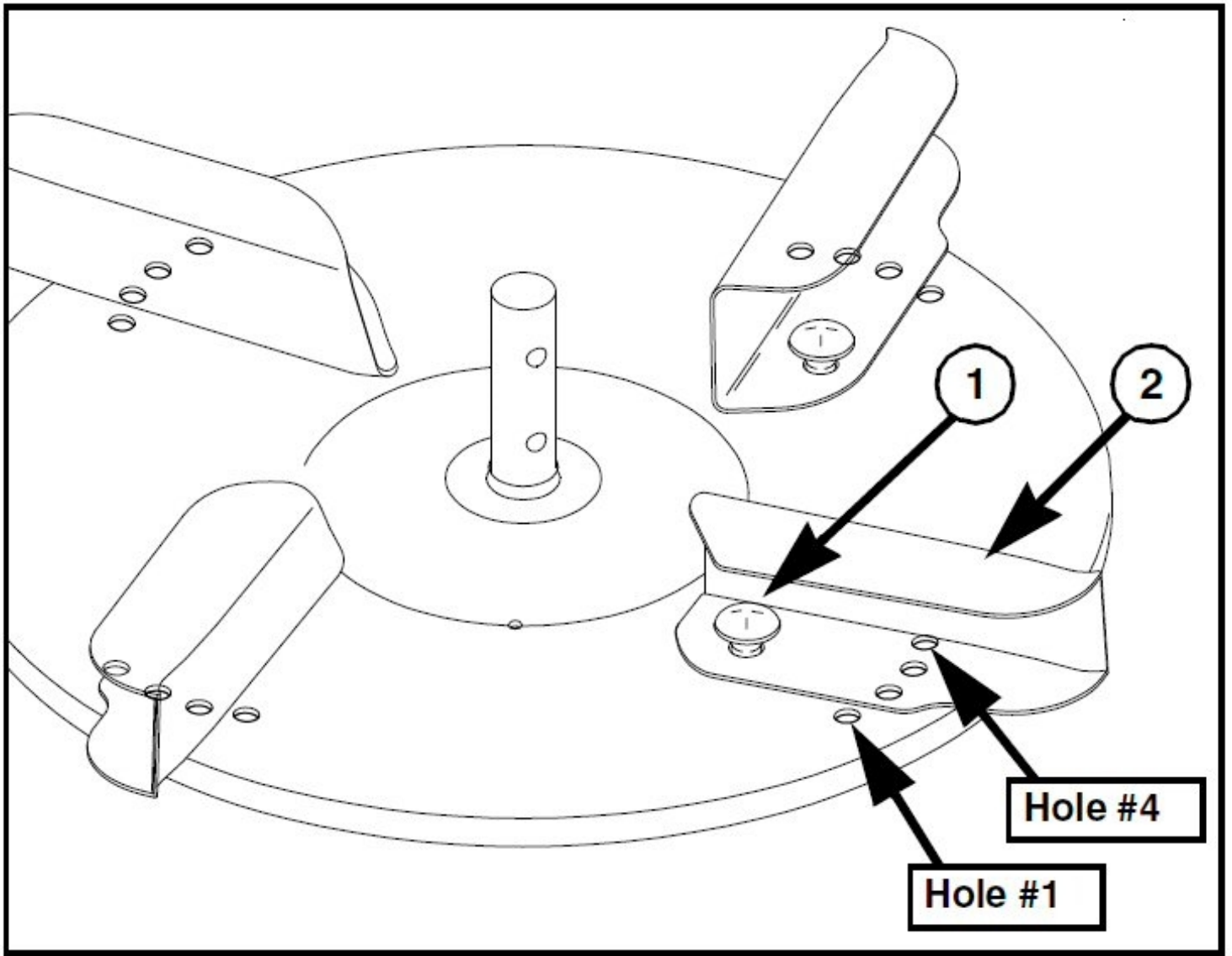

Distributor Vanes
Figure 3

NOTE: To distribute product more uniformly, operate spreader on calm (non windy) days.

NOTE: To ensure full coverage (without skips), set spreader to disperse product at half the rate and go over the field plot twice using a 2nd pattern that crosses the first pattern.

ADJUSTING THE SPREADING

1. With gates closed and tractor engine set at idle, engage power take-off to verify everything is running smoothly. Increase power take-off speed to 540 rpm to complete verification. Remember to disengage power take-off immediately and shut tractor down if Spreader vibrates excessively.
2. Shut power take-off and tractor down to continue field set-up.
3. Check to make certain spreader disc is level.
4. Make gate adjustments per instructions on chart.
5. Fill hopper with precise amount of material to cover one acre or hectare. Make a test run traveling at the speed you intend to apply product while dispersing it over a pre-marked area such as one acre or hectare to verify if any additional adjustments need to be made.
6. Adjust distributor vanes as needed.
7. Make a measurement of the spread pattern to be used later when applying product to the field.
8. Once all adjustments have been made and settings are satisfactory, lower hopper to ground and fill with product.
9. There are a variety of ways to spread product over a field. With D = spread pattern and $D/2$ = one half the spread pattern:
 - a. Start tractor (1) in a field corner at a distance equal to $(D/2)$ away from the field edge.
 - b. Maintain this half distance from the field edge as you travel around the complete perimeter of the field.
 - c. When approaching starting point (2), turn tractor when at distance (D) away from the first run and travel parallel to the first run until the tractor (#3) is at distance (D) away from end of field.
 - d. Once you reach distance (D) from end of field, stop power take-off, turn tractor, and drive forward until at distance (D) away from the last run and then turn the tractor (4) again to head back across the field.
 - e. Start power take-off when at distance (D) from the field edge and continue back parallel to the previous run until tractor (5) is again at distance (D) away from end of field.
 - f. Continue this back and forth pattern (2 to 3, 4 to 5, 6 to 7 etc.) until field plot has been covered.

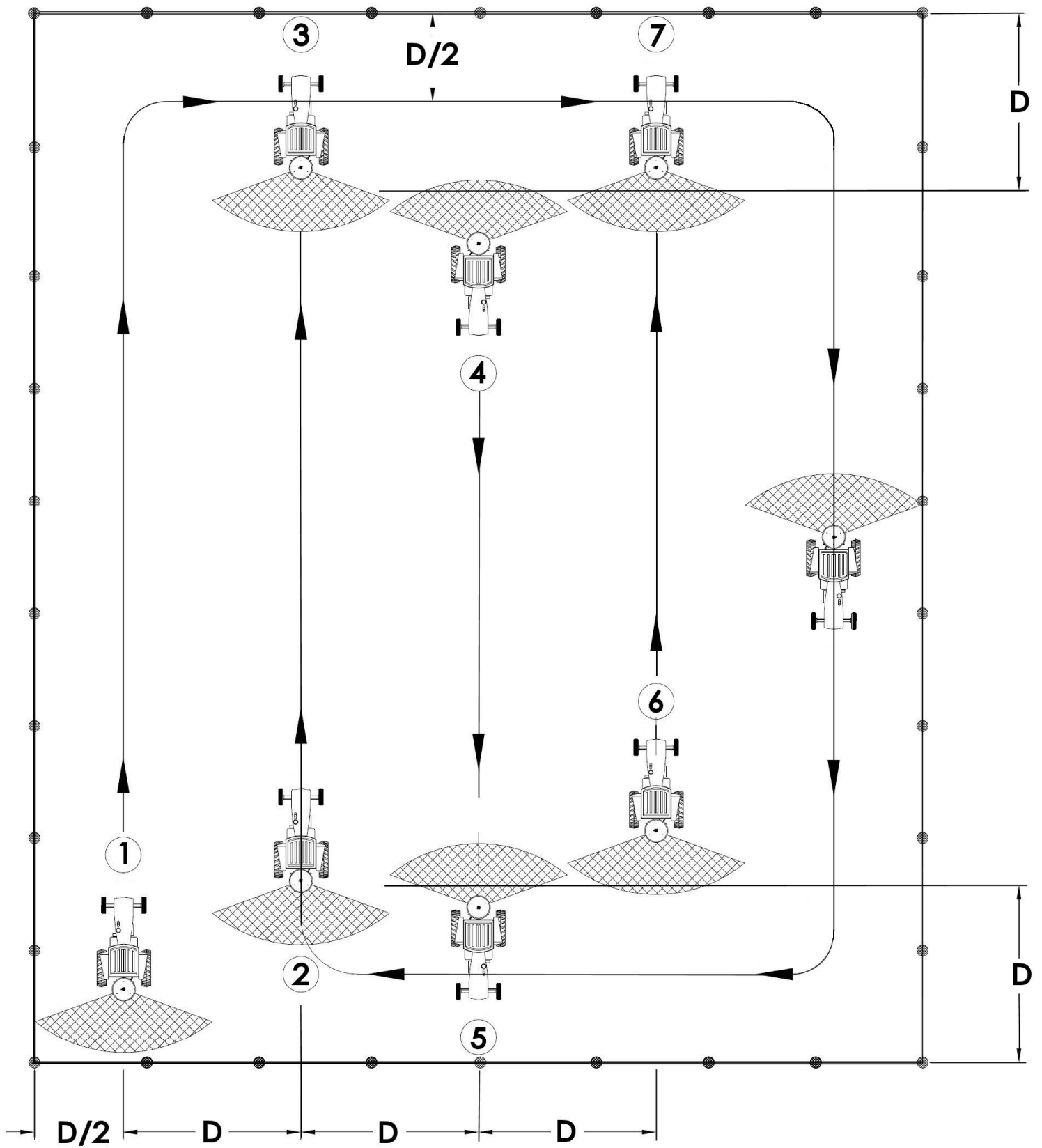

Application Pattern (Example)
Figure 1

Dispersal Pattern

Refer to Figure 3-1, Figure 3-2 & Figure 3-3:

Product dispersal is controlled by properly opening and closing left and right gates at the hopper bottom with adjustment levers (#1 & #2). Some adjustment to the distributor vanes may be required. See detailed instructions for “**Distributor Vane Adjustment**” on page 22 & 23.

Positioning right and left gate levers as follows:

Left Side Dispersal, View (A) in Figure 3-1

Refer to Figure 3-3:

1. Remove lever locking knob (#3).
2. Close right gate by moving adjustment lever (#1) above gate setting position #1.
3. Move adjustment lever (#2) to the selected gate setting provided in spread chart.
4. Secure adjustment lever (#2) by placing hair pin cotter (#5) in the selected gate setting hole with adjustment lever (#2) resting on top of hairpin (#5).

Full Width Dispersal, View (B) in Figure 3-1

Refer to Figure 3-2 & Figure 3-3:

1. Lock adjustment levers (#1 & #2) together with lever locking knob (#3).
2. Move adjustment levers together just above selected gate setting provided in spread chart.
3. Secure adjustment levers by placing hair pin cotter (#5) in the selected gate setting hole with adjustment levers resting on top of hairpin (#5).

Right Side Dispersal, View (C) in Figure 3-1

Refer to Figure 3-3:

1. Remove lever locking knob (#3).
2. Close left gate by moving adjustment lever (#2) up above gate setting position #1.
3. Move adjustment lever (#1) to the selected gate setting provided in spread chart.
4. Secure adjustment lever (#1) by placing hair pin cotter (#5) in the selected gate setting hole with adjustment lever (#1) resting on top of hairpin (#5).

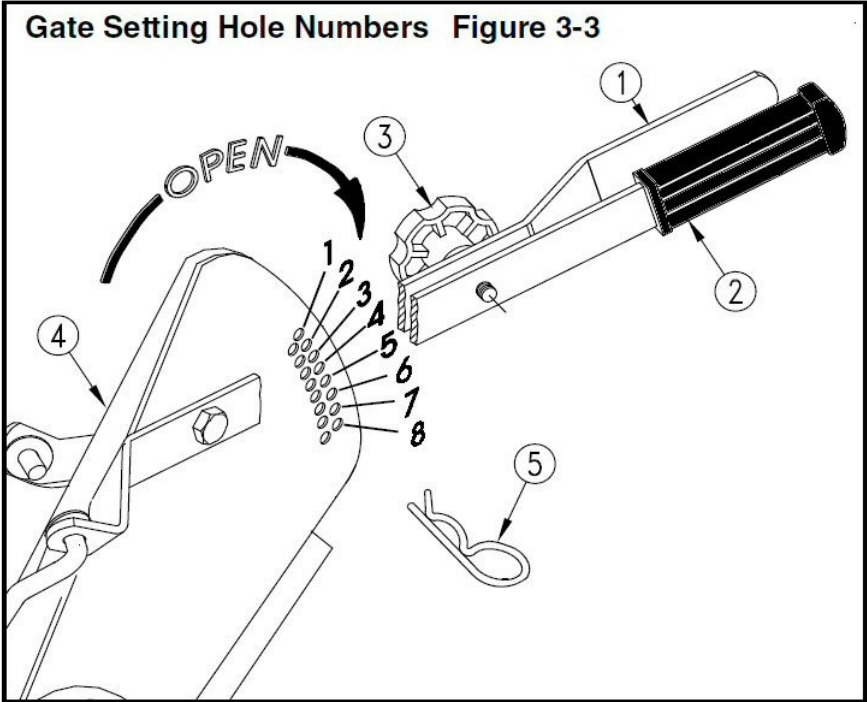
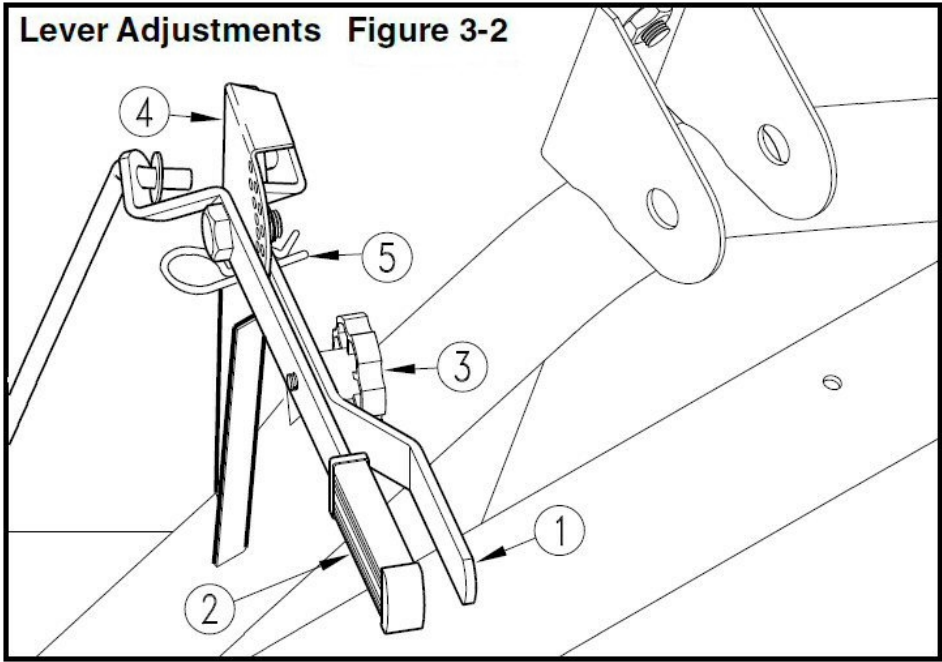
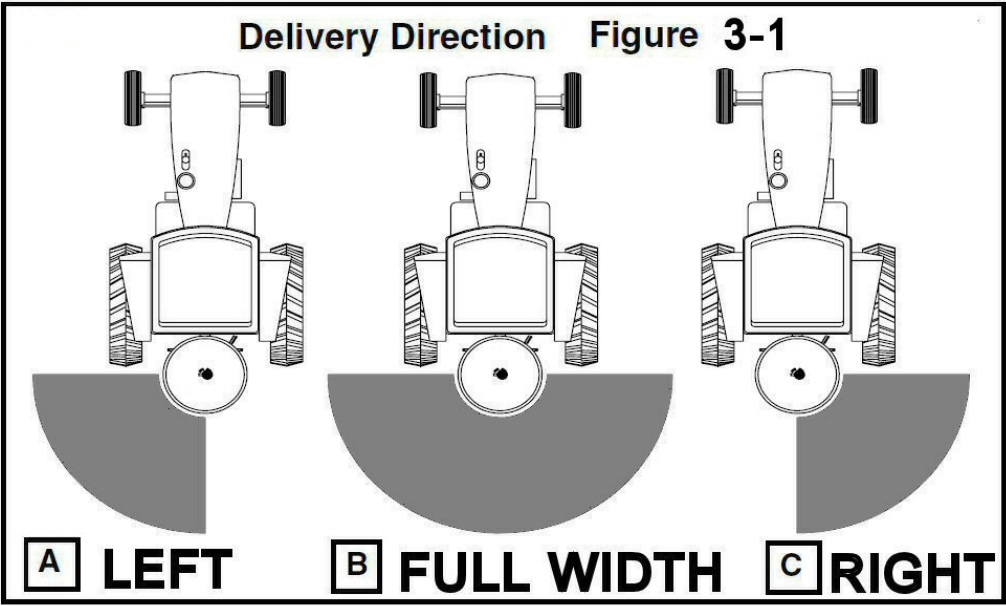

SPREADING MISTAKES

- Drive speed
- Incorrect spreading width:
- The spreading disc is not in horizontal position
- Drive speed is different than the table or not suitable for particular fertilizer
- Lack of cleaning of distributor discs and gates openings
- Poor quality fertilizer, Wet or humid
- Presence of excessive lumps
- Foreign body in the fertilizer
- Spreading exits clogged
- Parts of spreading disc worn or damaged

LUBRICATION

Before using the seeder for the first time, put at least **(35 shots with a hand grease gun)** of grease in zerk shown below. After every 8 hours of use put in **(3 to 4 shots with a hand grease gun)**. **DO NOT OVER FILL!**

Make sure the grease zerks are clean from dirt and other foreign materials before injecting the grease.

NOTE: Use only a grade Type II or Lithium tube grease.

P O I N T T O G R E A S E

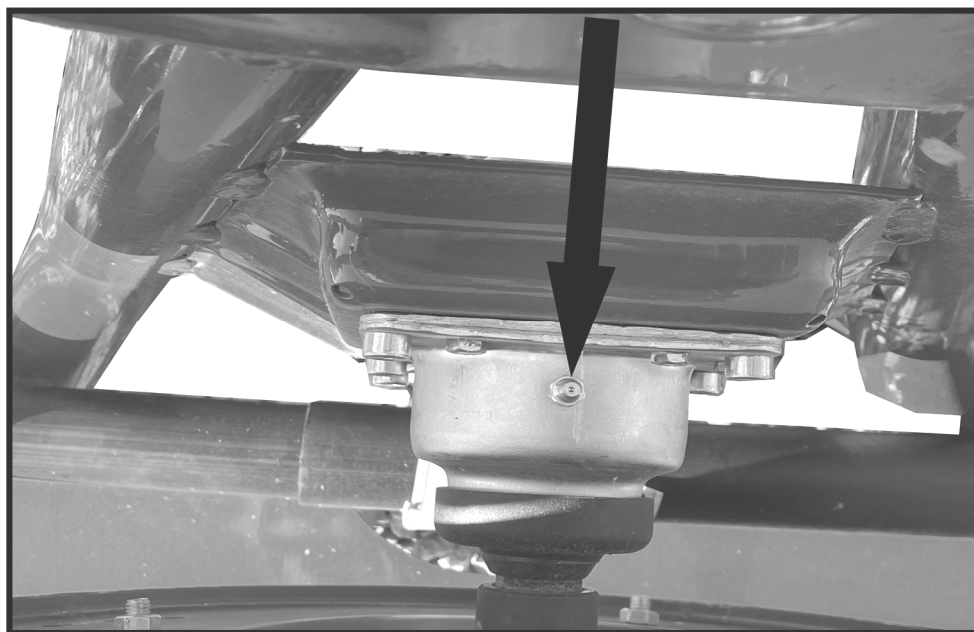

REPLACEMENT OF THE SPREADER VANES

In case the spreader vanes of the disc brake or get damaged, it will be necessary to replace them with new ones.

See Figure 4 Below

Unscrew the nut (#1) and replace the damaged vane (#2). The nuts and bolts you remove, if not damaged may be reused. If they are damaged or worn replace them with the same type and size nuts and bolts.

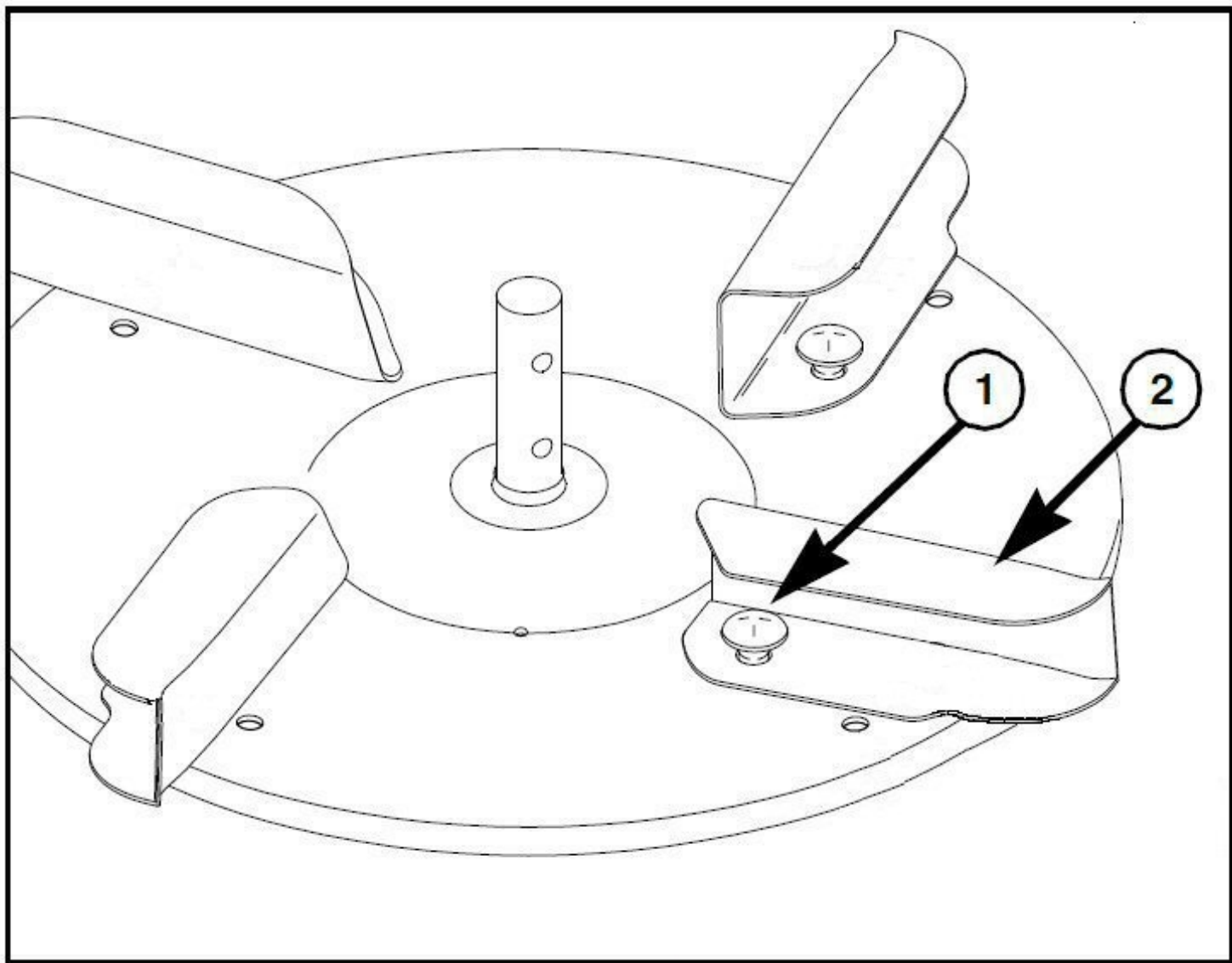

Distributor Vanes
Figure 4

SSX500 SEEDER DIAGRAM

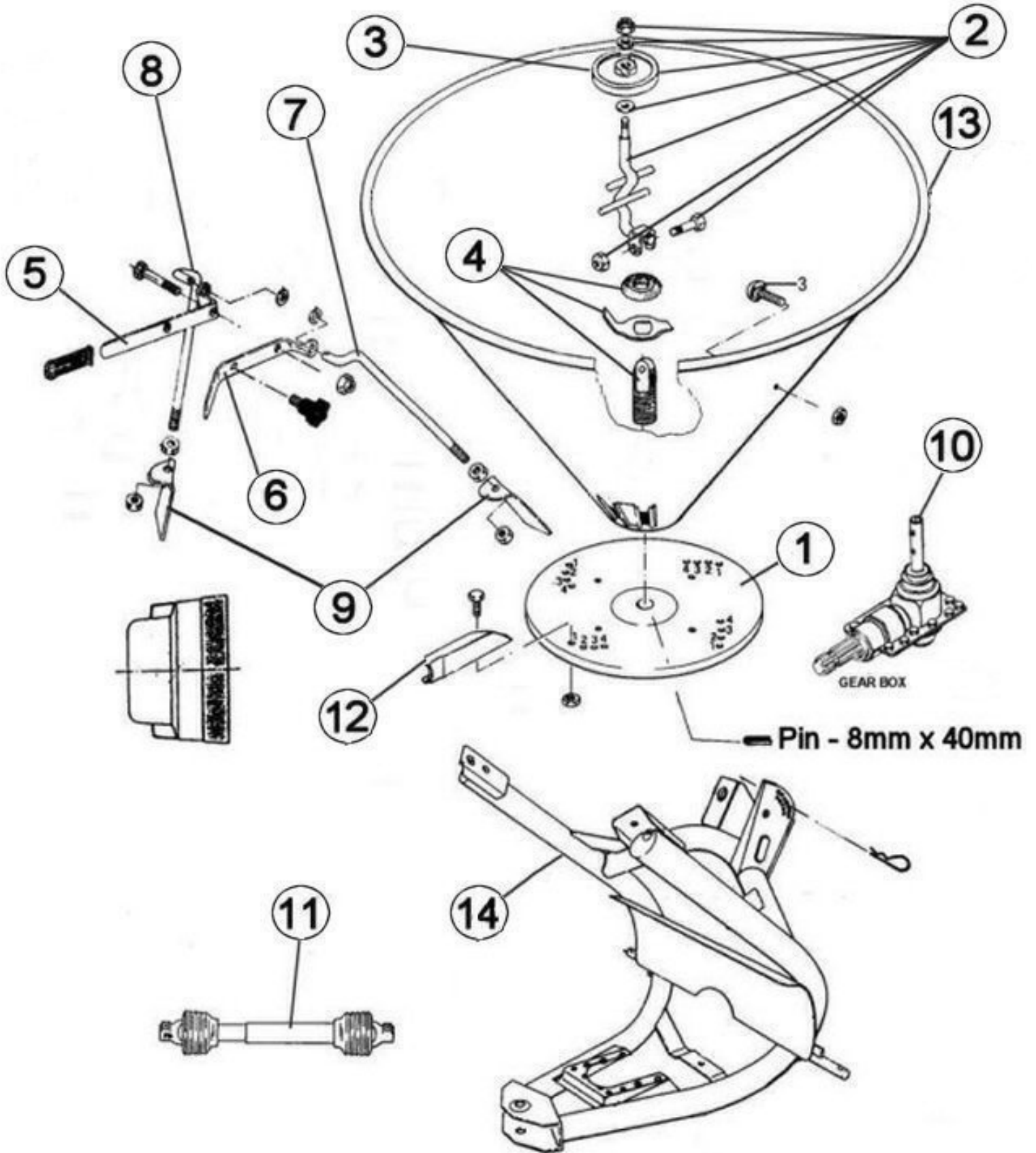

SSX500 SEEDER PARTS

Ref. No.	Model #	Part #
	Model #	SSX500
1	Spreader Disc W/Vanes	900004
2	Agitator	900138
3	Buffer Wheel	900005
4	Lower Agitator Kit	509000
5	LH Shutter Lever	900120
6	RH Shutter Lever	900122
7	RH Lever Tie Rod	900123
8	LH Lever Tie Rod	900121
9	Shutters (1-Left & 1- Right)	509001
10	Gearbox	900110
11	20" PTO Shaft	147020
12	Distributor Vanes (PK of 4)	509002
13	SSX500 Steel Hopper Black	900136
14	Seeder Frame	900135



1. Limited Warranty.

Summit Tractors LLC, 3379 Peachtree Road NE Suite 555 Atlanta, GA 30326, warrants to the original retail purchaser ("Purchaser") that the product that is the subject of this sale is free from defects in material and workmanship at the time of sale.

Under this warranty, Summit Tractors will repair the defective product free of charge to the Purchaser, with either new or used and reconditioned replacement parts. All warranty service will be performed at service centers designated by Summit Tractors. If Summit Tractors is unable to repair the product to conform to the warranty after a reasonable number of attempts, Summit Tractors will provide, at its option, one of the following: (a) a replacement for the product or, (b) a full refund of the purchase price. Repair, replacement, or refunds are the Purchaser's EXCLUSIVE remedies against Summit Tractors under this limited warranty. Summit Tractors will not be liable for any special, incidental or consequential damages based upon breach or warranty, breach of contract, negligence, strict tort liability, or any other legal theory. Such damages include, but are not limited to, loss of profits, loss of savings or revenue, loss of use of the product or any associated equipment, cost of capital, cost of any substitute equipment, facilities or services, down time, the claims of third parties including customers, and injury to property. These limitations also apply, to the extent allowed by law, to personal injury.

The purchaser must notify the Seller in writing of any defect in material or workmanship within one (1) year following the date of purchase. If the equipment is used for commercial purposes, the Purchaser must notify the Seller in writing of any defect in material or workmanship within ninety (90) days following the date of purchase. In no event will Summit Tractors be liable under this warranty unless written notice is received by the Seller within one (1) year from the date of original retail sale.

2. Warranty of Title.

Summit Tractors warrants that it transfers a good title to the product free of any encumbrances, and free of the rightful claim of any third party for infringement of patent or copyright.

3. What is Not Covered by This Limited Warranty.

Summit Tractors will not be responsible for damage to or failure in the product which results from accident, misuse, abuse, neglect, installation of attachments not provided by Summit Tractors, modifications to the product, or damage caused by use of the product for purposes other than those for which it was designed.

4. No Other Warranties.

Unless modified in writing and signed by both parties, this agreement is understood to be the complete and exclusive agreement and warranty between Summit Tractors and Purchaser, superseding all prior agreements, oral and written, and all other communication between Summit Tractors and Purchaser related to the subject matter of this agreement.

THIS LIMITED WARRANTY IS IN LIEU OF ALL OTHER WARRANTIES, EXPRESS OR IMPLIED, INCLUDING, BUT NOT LIMITED TO, THE IMPLIED WARRANTY OF MERCHANTABILITY AND THE IMPLIED WARRANTY OF FITNESS FOR A PARTICULAR PURPOSE. No employee of Summit Tractors nor anyone else is authorized to make any warranty or representation in addition to or different from those made in this agreement.

5. Allocation of Risk.

This agreement allocates the risk of product failure between Summit Tractors and the Purchaser. This Allocation is recognized by both parties as reflected in the price of the goods. The Purchaser acknowledges that he or she has read this agreement, understands it, and is bound by its terms.